

Prosurge's SP series surge arrester is UL1449-4th addition approved SPD especially designed for low-voltage power supply system surge protection at the boundaries from lightning protection zone 0<sub>B</sub>-2 and higher. It is a DIN-rail designed surge protective device featuring Prosurge's global patented design of thermally protected MOV with special arc-extinguish device, providing fast and reliable protection for various power supply systems. Modules feature a visual fault indicator and an optional remote alarm contact is available to monitor the operating status of the surge protector by signaling an alarm. The SP series has a very high short circuit current rating of 200kArms, which eliminates the requirement for additional overcurrent protection devices.

## Applications:

- Power Supplies
- Telecom
- Industrial Automation
- Railway Systems
- Photovoltaic (PV) Systems
- UPS Systems
- Electricity
- Electrical Vehicle Charging Station
- Water Treatment Systems
- Motor Control And Starter Systems
- AC/DC Distribution
- Programmable Logic Controller (PLC)
- Power Transfer Equipments
- HAVC Applications
- IT / Data Centers
- Applications-AC/DC Drives, LT Panels, MCC, PCC, CNC Machines, PLC Etc.
- Medical Equipments
- Security Systems

## Features:

- UL 1449-4th Edition Recognized Type 1CA SPD for Type 1, 2, and 3 Application, SCCR 200 kA
- Built-in Thermally Protected High Energy MOV Technology (Patented SMTMOV Technology)
- High Surge Energy Capability
- Low Voltage Protection Level
- Din-Rail Mountable For Easy Installation
- Degradation Failure Indication
- Fail-Safe, Self-Protected Design
- Pluggable Module For Easy Replacement
- No Additional Over-Current Protection Devices Required
- Meets Both Standards of UL1449-4th Edition and IEC61643-11:2011



## Power system graph:

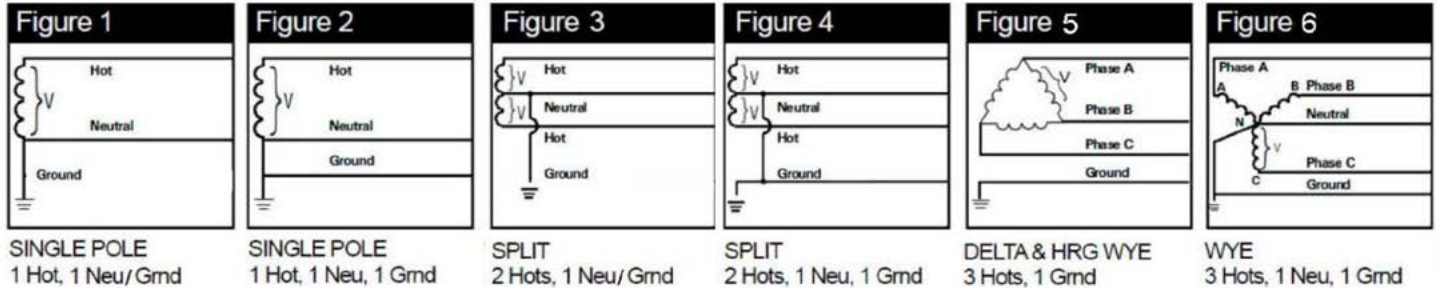

- Figure 3:** 120/240V Split-phase three-wire
- Figure 4:** 120/240V Split-phase three-wire + ground
- Figure 5:** 240V, 277V, 480V, 600V Three-phase delta & WYE three-wire + ground
- Figure 6:** 220Y/127V, 208Y/120V, 380Y/220V, 400Y/230V, 415Y/240V, 480Y/277V, 600Y/347V Three-phase WYE(star)four-wire+ground

## Wiring Diagrams:

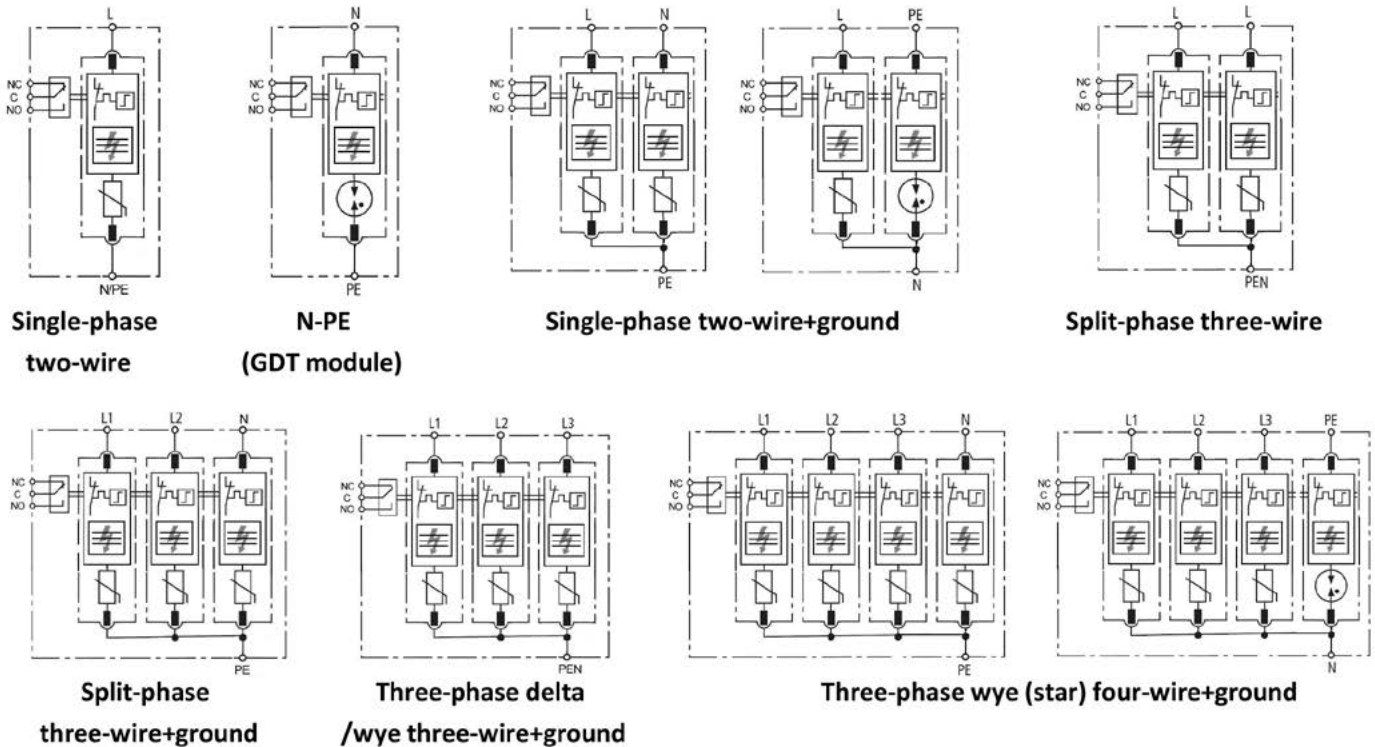

## General Product Specifications

Short-Circuit Current Rating	200 kA
Nominal discharge current(8/20)	20 kA
Maximum discharge current(8/20) I <sub>max</sub>	50 kA
Follow current	MOV model: Zero; GDT model: 200A self cutoff
Thermal disconnecter	Internal: green - normal ; red - failure
Wire Range	#12-6AWG Solid / Stranded CU
Mounting	35mm DIN-Rail
Degree of Protection	IP 20
Flammability	UL94 V0
Operating & Storage Temperature	- 40°C to + 80°C
Remote alarm contact	NO/NC/C, Isolated Form C
Remote alarm contact capability Un/In	AC: 250V/0.5A DC: 250V/0.1A; 75V/0.5A
Remote alarm contact connecting wire	Max. # 16AWG

## PD Models used for Single-Phase Two-Wire System

Part No	Poles	Nominal Voltage (Vac)	Maximum Continuous Operating Voltage, MCOV (Vac)			Voltage Protection Rating, VPR (kV)		
			L-N	L-G	N-G	L-N	L-G	N-G
SP150-1P	1	120	150	150	-	0.7	0.7	-
SP180-1P	1	127	180	180	-	1.0	1.0	-
SP275A-1P	1	240	275	275	-	1.0	1.0	-
SP320-1P	1	277	320	320	-	1.2	1.2	-
SP385-1P	1	277	385	385	-	1.5	1.5	-
SP420-1P	1	347	420	420	-	1.5	1.5	-
SP550-1P	1	480	550	550	-	1.8	1.8	-
SP690-1P	1	600	690	690	-	2.5	2.5	-
SP150T	1	0	-	-	150	-	-	0.9
SP255T	1	0	-	-	255	-	-	0.9

## SPD Models used for Split-Phase Two-Wire + Ground System

Part No	Poles	Nominal Voltage (Vac)	Maximum Continuous Operating Voltage, MCOV (Vac)			Voltage Protection Rating, VPR (kV)		
			L-N	L-G	N-G	L-N	L-G	N-G
SP180-2P*	2	120	180	180	180	2.0	1.0	1.0
SP320-2P*	2	277	320	320	320	2.5	1.2	1.2

\*This model is used for split phase applications for L-G protection mode.

## PD Models used for Split-Phase Three-Wire + Ground System

Part No	Poles	Nominal Voltage	Maximum Continuous Operating Voltage, MCOV (Vac)			Voltage Protection Rating, VPR (kV)		
		(Vac)	L1-G	L2-G	N-G	L1-G	L2-G	N-G
SP180-3P*	3	120	180	180	180	1.0	1.0	1.0
SP320-3P*	3	240	320	320	320	1.2	1.2	1.2

\*This model is used for split phase applications for L1 to G, L2 to G and N to G protection mode.

## PD Models used for Three-Phase Wye Three-Wire + Ground System

Part No	Poles	Nominal Voltage	Maximum Continuous Operating Voltage, MCOV (Vac)			Voltage Protection Rating, VPR (kV)		
		(Vac)	L-L	L-G	N-G	L-L	L-G	N-G
SP150-3P	3	120	300	150	-	1.5	0.7	-
SP180-3P	3	120	360	180	-	2.0	1.0	-
SP275A-3P	3	240	550	275	-	2.0	1.0	-
SP320-3P	3	277	640	320	-	2.5	1.2	-
SP385-3P	3	277	770	385	-	3.0	1.5	-
SP420-3P	3	347	840	420	-	3.0	1.5	-
SP550-3P	3	480	1000	550	-	4.0	1.8	-
SP690-3P	3	600	1000	690	-	5.0	2.5	-

## SPD Models used for Three-Phase Wye Four-Wire + Ground System

Part No	Poles	Nominal Voltage (Vac)	Maximum Continuous Operating Voltage, MCOV (Vac)			Voltage Protection Rating, VPR (kV)		
			L-L	L-N(G)	N-G	L-L	L-N	L(N)-G
SP150-4P	4	208/120	300	150	150	1.5	0.7	0.7
SP150-3PN	4		300	150	150*	1.5	0.7	0.9
SP180-4P	4	208/120	360	180	180	2.0	1.0	1.0
SP180-3PN	4		360	180	150*	1.5	0.9	0.9
SP275A-4P	4	415/240	550	275	275	2.0	1.0	1.0
SP275A-3PN	4		550	275	255*	2.0	1.0	0.9
SP320-4P	4	480/277	640	320	320	2.5	1.2	1.2
SP320-3PN	4		640	320	255*	2.5	1.2	0.9
SP385-4P	4	480/277	770	385	385	3.0	1.5	1.5
SP385-3PN	4		770	385	255*	3.0	1.5	0.9
SP420-4P	4	600/347	840	420	420	3.0	1.5	1.5
SP420-3PN	4		840	420	255*	3.0	1.5	0.9
SP550-4P	4	600/347	1000	550	550	4.0	1.8	1.8
SP690-4P	4	600/347	1000	690	690	5.0	2.5	2.5

## SPD Models used for Single-Phase Two-Wire + Ground System

Part No	Poles	Nominal Voltage (Vac)	Maximum Continuous Operating Voltage, MCOV (Vac)			Voltage Protection Rating, VPR (kV)		
			L-N	L-G	N-G	L-N	L-G	N-G
SP150-2P	2	120	150	150	150	1.5	0.7	0.7
SP150-PN	2		150	150	150	0.7	0.9	0.9
SP180-2P	2	120	180	180	180	2.0	1.0	1.0
SP180-PN	2		180	180	150	1.0	1.0	0.9
SP275A-2P	2	240	275	275	275	2.0	1.0	1.0
SP275A-PN	2		275	275	275	1.0	1.0	0.9
SP320-2P	2	277	320	320	320	2.5	1.2	1.2
SP320-PN	2		320	320	255	1.2	1.2	0.9
SP385-2P	2	277	385	385	385	3.0	1.5	1.5
SP385-PN	2	240	385	385	255	1.5	1.5	0.9
SP420-2P	2	347	420	420	420	3.0	1.5	1.5
SP420-PN	2	240	420	420	255	1.5	1.5	0.9
SP550-2P	2	480	1000	550	550	4.0	1.0	1.0
SP690-2P	2	600	690	690	690	5.0	5.0	2.5

**Dimensions:**

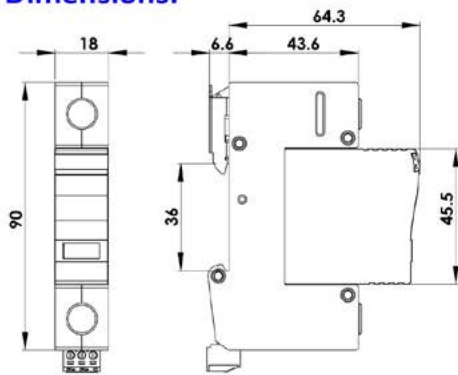

1Pole (18mm width)

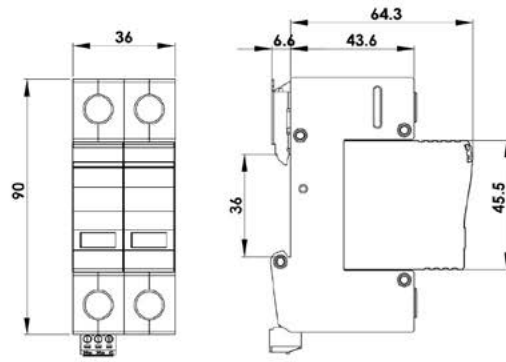

2Pole (36mm width)

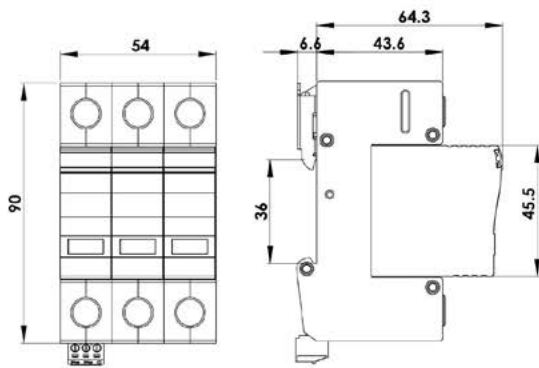

3Pole (54mm width)

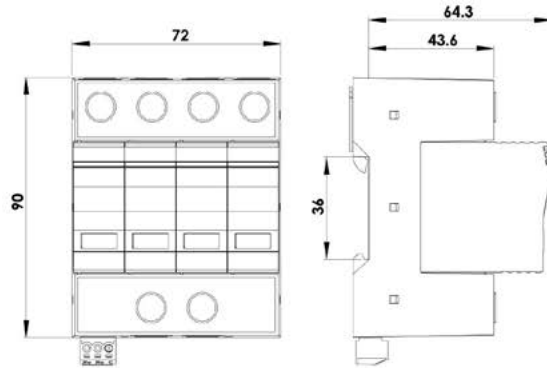

4Pole (72mm width)

**Visual Indicator & Remote Signal:**

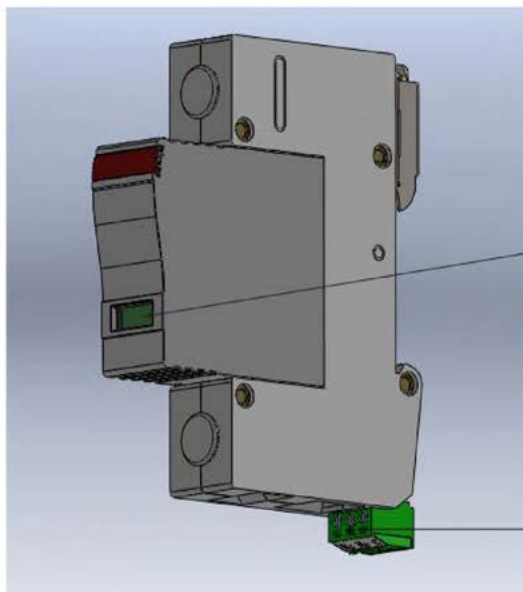

Visual Indicator (Green/Red)

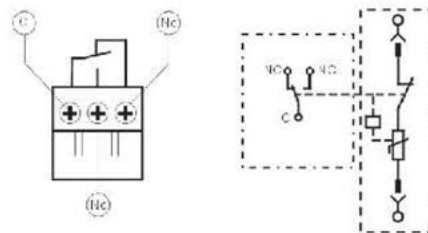

Red Mark & C-No connect	Fault, needs to be replaced
Green Mark & C-Nc connect	OK